



RatioMatic Burners

Model RM700

Version 3.10

Specifications

PARAMETER		SPECIFICATIONS			
Maximum input (Btu/hr) Note: Contact factory for varying chamber pressures or pressures outside the range: -5.0" to 5.0" w.c. (-12,4 to 12,4 mbar)	Frequency	BTU/hr	"w.c.	kW	mbar
	60 Hz*	7,640,000	-5.0	2240	-12,4
	Packaged Blower	7,260,000	-2.0	2130	-5,0
		7,000,000	0.0	2050	0,0
		6,720,000	2.0	1970	5,0
6,290,000		5.0	1840	12,4	
Minimum input		BTU/hr	kW		
		80,000	23		
Main Gas Inlet Pressure		psig		mbar	
• Fuel pressure at ratio regulator inlet	Natural gas	1.5 to 2.5	105 to 175		
	Propane	1.5 to 2.0	105 to 140		
High Fire Flame Length		inches		mm	
• Measured from the outlet end of combustor	Natural gas	75	1900		
	Propane	88	2200		
Maximum Chamber Temperature		°F		°C	
	Alloy Tube	1500	820		
	Block & holder	1900	1040		
Flame Detection		Flame rod or UV scanner			
	Alloy Tube	UV scanner only			
	Block & holder				
Fuel		Natural gas or Propane.			
		For any other gas, contact Eclipse Combustion for orifice sizing			

* For 50 Hz applications, use remote blower or consult factory.

- All information is based on laboratory testing. Different chamber size and conditions will affect the data.
- Maximum inputs are given for the standard combustion air blower without an air filter.
- All inputs based upon gross calorific values and standard conditions; 1 atmosphere, 70° F (21°C).
- Eclipse reserves the right to change the construction and/or configuration of our products at any time without being obliged to adjust earlier supplies accordingly.

Performance Graphs RatioMatic RM700

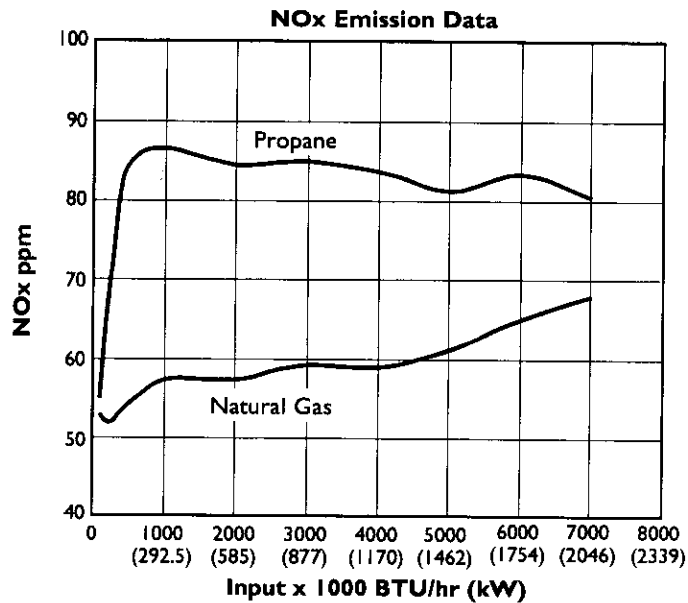
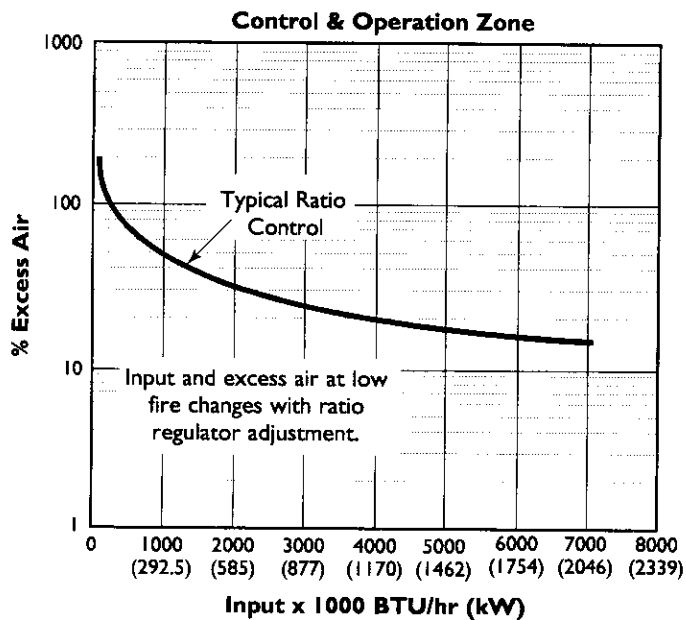

NOx emission data is given for:

- Ambient combustion air ~70° F (20° C)
- Less than 1000° F (540° C) firing chamber
- Minimal process air velocity
- Low fire input adjusted to 80,000 BTU/hr (23kW)
- ppm volume, dry @ 3% O₂
- Neutral chamber pressure

Emissions are influenced by:

- Chamber conditions
- Fuel type
- Firing rate
- Ratio regulator adjustment
- Combustion air temperature

CO emission is largely influenced by chamber conditions. Contact your local Eclipse Combustion representative for an estimate of CO emission on your application

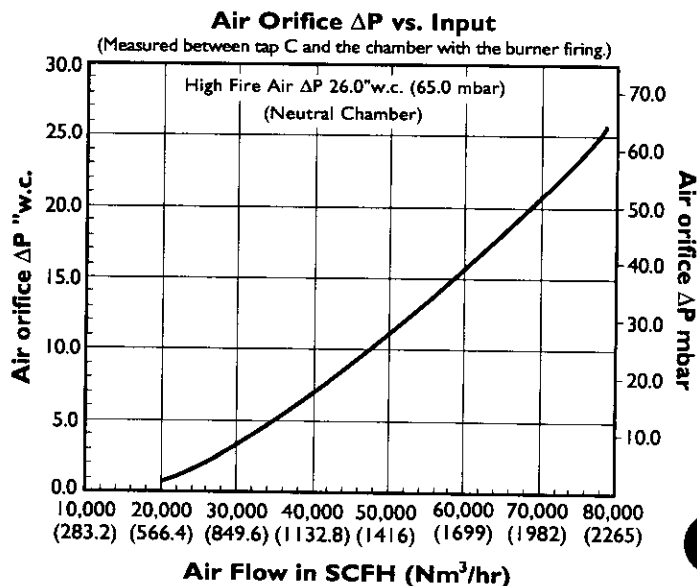
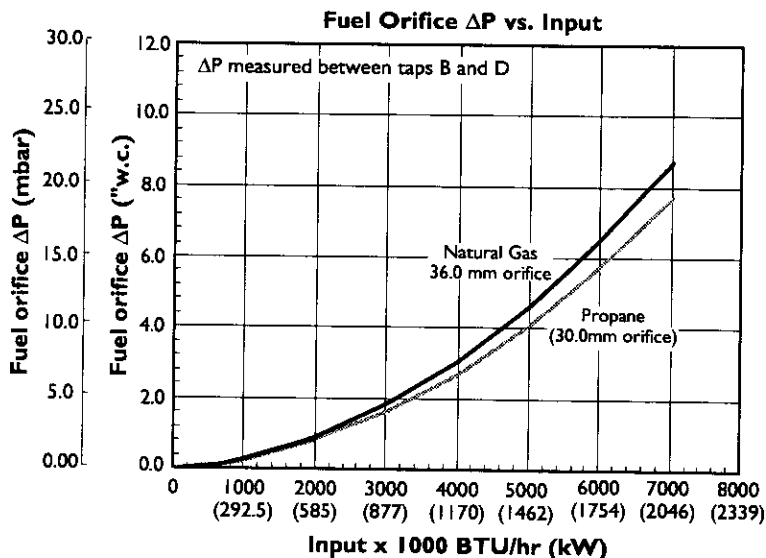

Dimensions-RM700

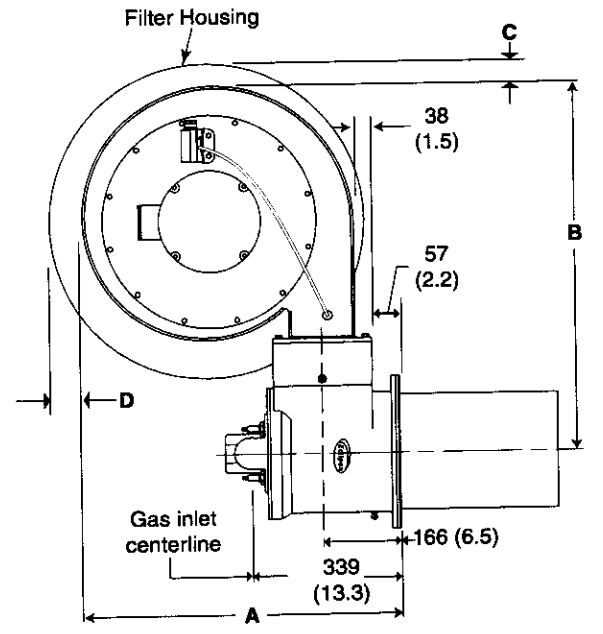
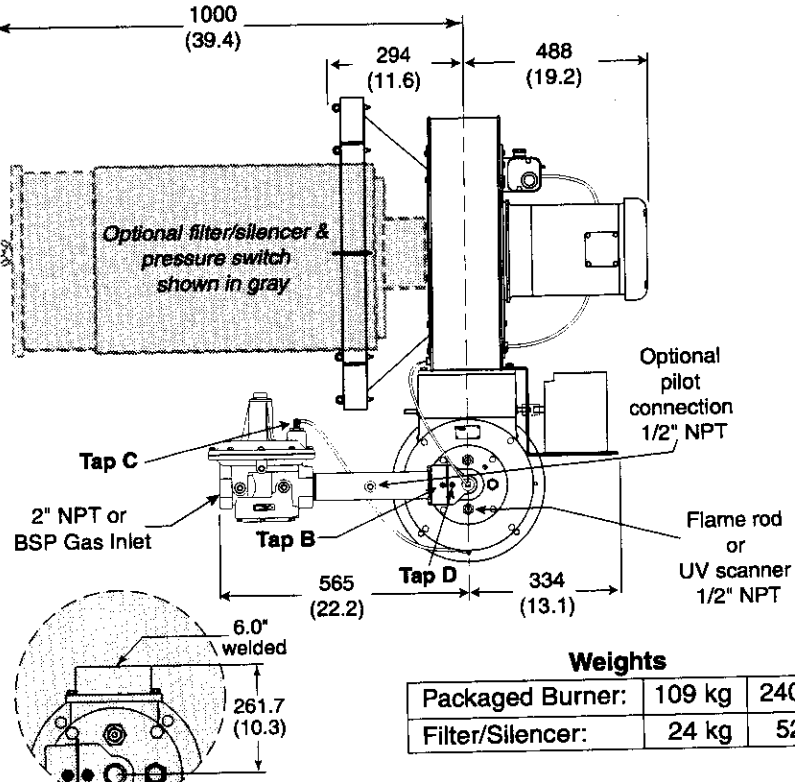

Weights

Packaged Burner:	109 kg	240 lb
Filter/Silencer:	24 kg	52 lb

A	B	C	D
698 (27.5)	893 (35.2)	12.5 (0.5)	28.5 (1.1)

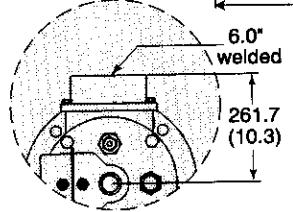

Less Blower Option

Combustor types

Alloy tube

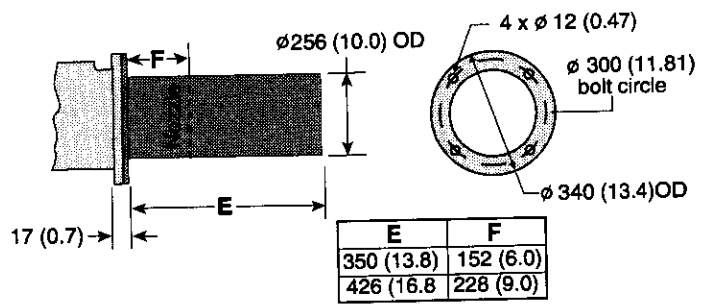

Block & Holder

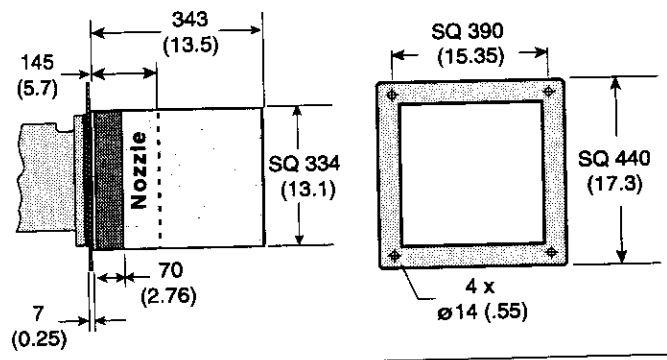

Burner configuration

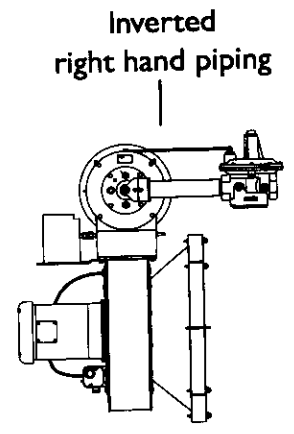
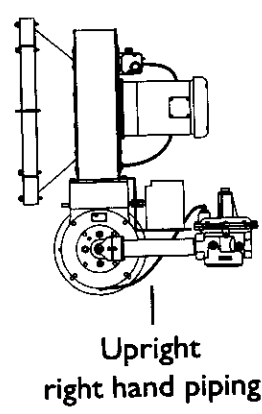
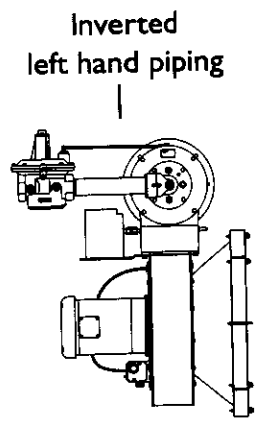
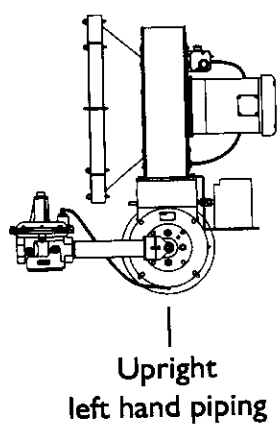



Offered By:

Power Equipment Company
2011 Williamsburg Road
Richmond, Virginia 23231
Phone (804) 236-3800
Fax (804) 236-3882

www.peconet.com